

> EVW

CONDENSERLESS UNITS FOR INDOOR INSTALLATION



Available range

Unit type

- IR Condenserless unit
- BR Condenserless unit Brine

Version

- VB Base version
- VD Desuperheaters version

Acoustic setting up

- AB Base setting up
- AS Low noise setting up

Unit description

This range of condenserless units are designed to meet the climate control and air conditioning needs of large capacity systems in the industrial and commercial sectors. All the units are suitable for indoor installation and can be applied to fan coil plants.

Suitable for indoor installation, as standard the units are equipped with 1 or 2 TWIN-SCREW semihermetic compressors mounted on rubber vibration dampers able to modulate the capacity from minimum 25 (not for all configurations) to 100%, plant side exchanger shell and tube type complete with Victaulic water connections, fitted inside a shell of thermal insulation material to prevent condensation and heat exchange with the outside, optimised for R134a with high efficiency grooved tubes, protected by means of a water differential pressure

switch, 1 or 2 independent refrigerant circuits, complete with electronic expansion valve which optimises unit efficiency at full and partial loads and enables maximum seasonal efficiency, maximum and minimum pressure switch, PED safety valves, dehydrator filter, liquid/moisture indicator, compressor discharge and liquid shut-off valves, high and low pressure transducers, electrical panel with minimum protection IP54 containing the electrical equipment and all the components to control and command the unit complete with main supply breaker with door lock function, phase sequence control device, microprocessor controller with display (4 lines of 20 characters).

The units can be selected as Base setting up (AB) or as Low noise setting up (AS) that provides that compressor are positioned inside a soundproofed cabin, made with profiles and panels insulated with acoustic material.

The units are suitable to be combined with remote condensers cooled by air (coil and fans) or remote condensers cooled by water (plate or shell and tube heat exchanger). The electronic controller can manage the numerous ways used on the market for the head pressure control for condensation by air and for condensation by water. A wide range of options and accessories completes the commercial offer. All the units are carefully built in compliance with the current regulations and individually tested.

The units are supplied with charge of NITROGEN in order to avoid the entrance of air inside the refrigerant circuit.

Options

Compressor starting

- standard (contactors)
- soft starter

Compressors power factor correction

Electrical load protection

- standard (fuses)
- thermal magnetic circuit breakers

Evaporator flow switch (mounted)

Evaporator insulation higher thickness

Evaporator electrical heater for winter antifreeze

High and low pressure gauges

Compressor suction shut-off valve

Accessories

Rubber vibration dampers

External Water Storage Tank and Pumping Module complete with insulated carbon steel tank, single or twin pump and all hydronic components.

Antifreeze electrical heaters for Storage tank

Remote controller

Serial Interface Modbus on RS 485

Programmer clock

Phase sequence and voltage controller

Water flow switch

Remote condenser cooled by air

CONTROL SYSTEM

The units are equipped with a controller designed to ensure energy saving and unit efficiency.

Available functions :

- Double Set Point
- Demand Limit
- Dinamic set point
- Condensation control
- Remote stand by



NET NOMINAL performances - Standard plants

IR		280.1	320.1	360.1	420.1	480.1	540.1	600.1	710.2	820.2	950.2	1100.2	1200.2	
C45W7	Cooling capacity	263	291	330	382	444	502	551	661	764	888	1001	1103	kW
	Power input	67,1	73,7	84,2	97	113	128	142	170	195	227	259	280	kW
	EER	3,92	3,95	3,92	3,95	3,93	3,92	3,89	3,88	3,93	3,92	3,87	3,93	W/W
	Water flow rate source side	12,7	14,0	15,9	18,3	21,4	24,1	26,5	31,8	36,7	42,8	48,3	53,0	l/s
	Pressure drops source side	41	32	40	38	48	38	47	47	40	52	53	41	kPa
C50W7	Cooling capacity	248	275	312	359	420	472	520	623	719	840	943	1042	kW
	Power input	73,4	80,2	91,8	105	124	139	154	185	211	249	281	307	kW
	EER	3,37	3,42	3,40	3,42	3,38	3,39	3,38	3,36	3,41	3,37	3,36	3,40	W/W
	Water flow rate source side	11,9	13,2	15,0	17,2	20,2	22,7	25,0	30,0	34,5	40,4	45,4	50,1	l/s
	Pressure drops source side	36	28	36	34	43	34	42	41	35	47	47	36	kPa

Data declared according to **EN 14511**. The values are referred to units without options and accessories.

EER (Energy Efficiency Ratio) = ratio of the total cooling capacity to the effective power input of the unit

C50W7 = condensing temperature (dew point) = 50 °C - subcooling = 5°C - plant : water in 12°C out 7°C

C45W7 = condensing temperature (dew point) = 45 °C - subcooling = 5°C - plant : water in 12°C out 7°C

Desupeheater Version (VD) - NET NOMINAL performances

IR		280.1	320.1	360.1	420.1	480.1	540.1	600.1	710.2	820.2	950.2	1100.2	1200.2	
C45W7 - W45	Cooling capacity	274	303	343	397	461	522	573	687	794	923	1041	1147	kW
	Total power input	65	72	82	94	110	125	138	166	189	221	252	273	kW
	EER	4,19	4,22	4,19	4,22	4,19	4,19	4,15	4,14	4,19	4,17	4,12	4,20	W/W
	HRE	5,11	5,15	5,11	5,14	5,10	5,11	5,07	5,06	5,11	5,09	5,04	5,12	W/W
	Water flow rate	13,2	14,5	16,5	19,1	22,2	25,1	27,6	33,1	38,2	44,5	50,2	55,2	l/s
	Water pressure	44	34	43	41	52	41	51	50	43	57	57	44	kPa
	Heating recovery capacity	60,2	66,5	75,7	86,9	101,1	115	127	152	175	202	231	252	kW
	Water flow rate recovery	2,88	3,18	3,61	4,15	4,83	5,50	6,05	7,27	8,35	9,66	11,0	12,0	l/s
	Water pressure drop recovery	8	9	9	12	11	9	11	9	12	11	9	10	kPa
	C50W7 - W45	Cooling capacity	257	286	325	373	437	491	541	647	747	873	980	1083
Total power input		71	78	89	102	121	136	150	180	205	243	274	299	kW
EER		3,60	3,66	3,63	3,65	3,61	3,62	3,60	3,59	3,65	3,59	3,58	3,63	W/W
HRE		4,53	4,59	4,56	4,58	4,53	4,55	4,53	4,52	4,58	4,51	4,50	4,56	W/W
Water flow rate		12,4	13,7	15,6	17,9	21,0	23,6	26,0	31,2	35,9	42,0	47,2	52,1	l/s
Water pressure		39	30	39	37	47	37	46	45	38	50	51	39	kPa
Heating recovery capacity		66,3	72,8	82,9	95,1	111,9	126	139	167	190	224	252	277	kW
Water flow rate recovery		3,17	3,48	3,96	4,54	5,35	6,02	6,63	7,97	9,09	10,71	12,1	13,2	l/s
Water pressure drop recovery		9	11	11	14	13	10	13	11	14	13	10	13	kPa

Data declared according to **EN 14511**. The values are referred to units without options and accessories.

EER (Energy Efficiency Ratio) = ratio of the total cooling capacity to the effective power input of the unit

HRE (Heat Recovery Efficiency) = ratio of the total capacity of the system (heating plus cooling capacity) to the effective power input

C50W7-W45 = condensing temperature (dew point) = 50 °C - subcooling = 5°C - plant : water in 12°C out 7°C / Recovery : water in 40°C out 45°C

C45W7-W45 = condensing temperature (dew point) = 45 °C - subcooling = 5°C - plant : water in 12°C out 7°C / Recovery : water in 40°C out 45°C

Acoustic performances

Base setting up (AB)	280.1	320.1	360.1	420.1	480.1	540.1	600.1	710.2	820.2	950.2	1100.2	1200.2	
Sound power level	97	97	97	98	98	98	98	99	100	100	100	100	dB(A)
Sound pressure level at 1 meter	79	79	79	80	80	80	80	80	81	81	81	81	dB(A)
Sound pressure level at 5 meters	70	70	70	72	72	72	71	72	73	73	73	73	dB(A)
Sound pressure level at 10 meters	65	65	65	67	67	67	66	67	68	68	68	68	dB(A)
Low noise setting up (AS)	280.1	320.1	360.1	420.1	480.1	540.1	600.1	710.2	820.2	950.2	1100.2	1200.2	
Sound power level	92	93	92	93	93	94	94	94	95	95	96	96	dB(A)
Sound pressure level at 1 meter	74	75	74	75	75	76	76	75	76	76	77	77	dB(A)
Sound pressure level at 5 meters	65	66	65	66	66	67	67	67	68	68	69	69	dB(A)
Sound pressure level at 10 meters	60	61	60	61	61	62	62	62	63	63	64	64	dB(A)

The acoustic performances are referred to units operating in cooling mode at nominal conditions C50W7.

Unit placed in free field on reflecting surface (directional factor equal to 2).

The sound power level is measured according to ISO 9614 standard.

The sound pressure level is calculated according to ISO 3744 and is referred to a distance of 1/5/10 metres from the external surface of the unit.

Technical data

Unit	280.1	320.1	360.1	420.1	480.1	540.1	600.1	710.2	820.2	950.2	1100.2	1200.2	
Power supply	400 - 3 - 50												V-ph-Hz
Max working pressure (HP-PS)	20												bar
Compressor type	twin-screw												-
N° compressors / N° refrigerant circuits	1 / 1						2 / 2						n°
Part load	25 / 100% continuous									12.5 / 100% continuous			
Plant side heat exchanger typex	shell and tube												-
IN/OUT Plant side hydraulic fittings	DN125	DN125	DN125	DN150	DN150	DN150	DN200	DN150	DN200	DN200	DN200	DN200	-
Refrigerant liquid line fitting	1x42	1x42	1x42	1x42	1x42	1x54	1x54	2x42	2x42	2x42	2x54	2x54	n° x Ø
Refrigerant gas line fitting	1x67	1x67	1x67	1x67	1x67	1x76	1x76	2x67	2x67	2x67	2x76	2x76	n° x Ø

Electrical data

Standard unit	280.1	320.1	360.1	420.1	480.1	540.1	600.1	710.2	820.2	950.2	1100.2	1200.2	
FLA - Full load current at maximum tolerated conditions	162	181	211	232	270	309	340	422	464	540	618	680	A
FLI - Full load power input at maximum tolerated conditions	99	110	129	144	169	190	209	257	287	339	380	418	kW
MIC - Maximum instantaneous current of the unit	520	612	665	436	465	586	650	876	668	735	895	990	A

Operating range

Temperature	Unit type	Cooling	
		min	max
Condensing temp (dew point)	IR, BR	30	60
Water outlet temperature plant side	IR	5	15
Water outlet temperature plant side	BR	-8	5

DIMENSIONS - MINIMUM OPERATING AREA - WEIGHT

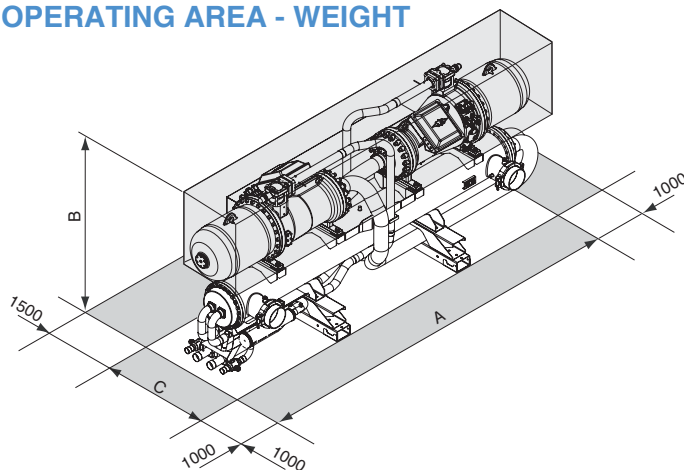

Model	280.1	320.1	360.1	420.1	480.1	540.1	600.1	710.2	820.2	950.2	1100.2	1200.2	
A	3900	3900	3900	3900	3900	3900	3900	4320	4400	4400	4400	4400	mm
B	1845	1845	1845	1880	1880	2045	2045	1845	1880	1880	2045	2045	mm
C	1100	1100	1100	1100	1100	1100	1100	1190	1190	1190	1230	1230	mm
Operating maximum weight	1651	1669	1682	2249	2263	2329	2633	3105	4334	4367	4569	4635	kg

Remote condenser

This series of Remote Axial Condensers uses copper pipes with special internal riffling and a high efficiency fin.

The fin has been specially designed to guarantee a high thermal exchange coefficient with low air pressure drops. By combining both special tubes and fins the following features can be achieved:

- Maximum capacity related to the heat exchanger's dimensions.
- Minimum refrigerant charge.
- The most strict environment standards for sound pollution can be met.

This new series of axial condensers is equipped with fans with scythe-shaped blades to reduce the sound emission. From the noise level point of view, all models can be supplied as basic version (AB), low noise version (AS) or extra low noise version (AX).

To guarantee solidity, strength and the maximum resistance to atmospheric agents the bearing and the casing are



manufactured with galvanized steel and oven painted with a polyurethane resin (the standard colour is RAL 7035).

Options

- Special fins (Copper, Painted Aluminium, ecc.).
- Special motors
- Vertical / Horizontal air flow
- EC fans

Accessories

All models can be equipped with several accessories as:

- Rubber Vibrations Dampers
- Modulating control of the fans with cut of phase regulator
- Modulating control of the fans with inverter regulator
- Electrical Wiring Box, allows a fast and safe electrical installation of the unit since all wires and thermal protections of the fans are connected inside a waterproof box (IP54) to a terminal block where the installer connect the electrical supply and the fans thermal switches signal.
- Electrical Panel CE this accessory (like the electrical wiring box) allows a fast and safe electrical installation and moreover simplify the standard and non standard maintenance of the unit.

The accessory is in fact composed by main electrical switch, fuses and contactors of the fans, transformer to supply an alarm auxiliary relè, terminal block for remote ON-OFF (i.e. sent by the condenserless unit).

Technical data

Unit	280.1	320.1	360.1	420.1	480.1	540.1	600.1	710.2	820.2	950.2	1100.2	1200.2	
Power supply	400 - 3 - 50												V-ph-Hz
Fan type	axial												-
Max working pressure (PS)	30												bar
Exchanger type	Aluminum fins and copper tubes												-

Acoustic performances

Base setting up (AB)	280.1	320.1	360.1	420.1	480.1	540.1	600.1	710.2	820.2	950.2	1100.2	1200.2	
Sound power level	86	88	88	88	89	89	90	90	91	91	93	99	dB(A)
Sound pressure level at 1 meter	70	72	72	72	73	73	74	74	74	74	76	82	dB(A)
Sound pressure level at 5 meters	59	61	61	61	62	62	63	63	63	63	65	71	dB(A)
Sound pressure level at 10 meters	54	56	56	56	57	57	58	58	58	58	60	66	dB(A)
Low noise setting up (AS)	280.1	320.1	360.1	420.1	480.1	540.1	600.1	710.2	820.2	950.2	1100.2	1200.2	
Sound power level	81	81	81	82	82	83	83	84	84	86	90	90	dB(A)
Sound pressure level at 1 meter	65	65	65	66	66	67	67	67	67	69	73	73	dB(A)
Sound pressure level at 5 meters	54	54	54	55	55	56	56	56	56	58	62	62	dB(A)
Sound pressure level at 10 meters	49	49	49	50	50	51	51	51	51	53	57	57	dB(A)
eXtra low noise setting up (AX)	280.1	320.1	360.1	420.1	480.1	540.1	600.1	710.2	820.2	950.2	1100.2	1200.2	
Sound power level	74	74	74	75	75	76	76	77	76	76	83	83	dB(A)
Sound pressure level at 1 meter	58	58	58	59	59	59	59	60	59	59	66	66	dB(A)
Sound pressure level at 5 meters	47	47	47	48	48	48	48	49	48	48	55	55	dB(A)
Sound pressure level at 10 meters	42	42	42	43	43	43	43	44	43	43	50	50	dB(A)

Remote condensers technical data

Base setting up (AB)		280.1	320.1	360.1	420.1	480.1	540.1	600.1	710.2	820.2	950.2	1100.2	1200.2	
Refrigerant connections	Gas	2x42	2x54	2x54	2x54	2x54	2x54	2x64	2x64	2x76	2x76	2x76	2x76	n° x Ø
	Liquid	2x35	2x42	2x42	2x42	2x35	2x42	2x42	2x42	2x42	2x54	2x54	2x54	n° x Ø
Fan specification	Fan	4	6	6	6	8	8	10	10	12	14	16	12	n°
	Diameter	800	800	800	800	800	800	800	800	800	800	800	900	mm
	Air flow rate	19667	31667	31667	29500	42222	39333	52778	49167	59000	68833	78667	100667	l/s
	Power input	8	12	12	12	16	16	20	20	24	28	32	43.2	kW
Standard configuration	Type	1											2	-
	Length [L]	3230	4580	4580	4580	5930	5930	7280	7280	8630	9980	11330	7990	mm
	Height [A]	2390	2390	2390	2390	2390	2390	2390	2390	2390	2390	2390	2262	mm
	Depth [P]	800	800	800	800	800	800	800	800	800	800	800	2400	mm
	Weight	543	742	742	804	982	1065	1222	1325	1585	1845	2106	2879	kg
Configuration with support brackets	Type	3											-	-
	Length [L]	3230	4580	4580	4580	5930	5930	7280	7280	8630	9980	11330	-	mm
	Height [A]	1565	1565	1565	1565	1565	1565	1565	1565	1565	1565	1565	-	mm
	Depth [P]	2400	2400	2400	2400	2400	2400	2400	2400	2400	2400	2400	-	mm
	Weight	569	768	768	830	1021	1104	1261	1364	1637	1897	2158	-	kg
Low noise setting up (AS)		280.1	320.1	360.1	420.1	480.1	540.1	600.1	710.2	820.2	950.2	1100.2	1200.2	
Refrigerant connections	Gas	2x54	2x54	2x54	2x54	2x54	2x64	2x64	2x76	2x76	2x76	2x76	2x76	n° x Ø
	Liquid	2x42	2x42	2x42	2x35	2x42	2x42	2x42	2x42	2x54	2x54	2x54	2x54	n° x Ø
Fan specification	Fan	6	6	6	8	8	10	10	12	14	16	12	12	n°
	Diameter	800	800	800	800	800	800	800	800	800	800	900	900	mm
	Air flow rate	24667	24667	22500	32889	30000	41111	37500	45000	52500	60000	87000	82333	l/s
	Power input	12	12	7.62	10.16	10.16	12.7	12.7	15.24	17.78	20.32	29.4	29.4	kW
Standard configuration	Type	1											2	-
	Length [L]	4580	4580	4580	5930	5930	7280	7280	8630	9980	11330	7990	7990	mm
	Height [A]	2390	2390	2390	2390	2390	2390	2390	2390	2390	2390	2262	2262	mm
	Depth [P]	800	800	800	800	800	800	800	800	800	800	2400	2400	mm
	Weight	742	742	804	982	1065	1222	1325	1585	1845	2106	2879	3056	kg
Configuration with support brackets	Type	3											-	-
	Length [L]	3230	4580	4580	4580	5930	5930	7280	7280	8630	9980	-	-	mm
	Height [A]	1565	1565	1565	1565	1565	1565	1565	1565	1565	1565	-	-	mm
	Depth [P]	2400	2400	2400	2400	2400	2400	2400	2400	2400	2400	-	-	mm
	Weight	768	768	830	1021	1104	1261	1364	1637	1897	2158	-	-	kg
eXtra low noise setting up (AX)		280.1	320.1	360.1	420.1	480.1	540.1	600.1	710.2	820.2	950.2	1100.2	1200.2	
Refrigerant connections	Gas	2x42	2x54	2x54	2x64	2x64	2x76	2x76	2x76	2x76	2x76	2x76	2x76	n° x Ø
	Liquid	2x35	2x35	2x42	2x42	2x42	2x42	2x54	2x54	2x64	2x64	2x64	2x64	n° x Ø
Fan specification	Fan	8	8	8	10	10	12	14	16	14	14	14	14	n°
	Diameter	800	800	800	800	800	800	800	800	800	900	900	900	mm
	Air flow rate	25778	23111	21333	28889	26667	32000	40444	46222	56389	52500	70000	70000	l/s
	Power input	4.7	4.7	4.7	5.9	5.9	7.1	8.3	9.4	9.5	9.5	15.5	15.5	kW
Standard configuration	Type	1											2	-
	Length [L]	5930	5930	5930	7280	7280	8630	9980	11380	9240	9240	9240	9240	mm
	Height [A]	2390	2390	2390	2390	2390	2390	2390	2390	2262	2262	2262	2262	mm
	Depth [P]	800	800	800	800	800	800	800	800	800	2400	2400	2400	mm
	Weight	900	982	1065	1222	1325	1585	1702	1942	3309	3515	3515	3515	kg
Configuration with support brackets	Type	3											-	-
	Length [L]	5930	5930	5930	7280	7280	8630	9980	11380	9240	9240	-	-	mm
	Height [A]	1565	1565	1565	1565	1565	1565	1565	1565	1565	1565	-	-	mm
	Depth [P]	2400	2400	2400	2400	2400	2400	2400	2400	2400	2400	-	-	mm
	Weight	939	1021	1104	1261	1364	1637	1754	1994	-	-	-	-	kg

Standard configuration type 1 (horizontal air flow)

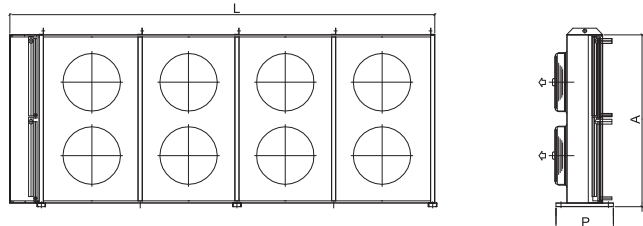

Standard configuration type 2 (vertical air flow)

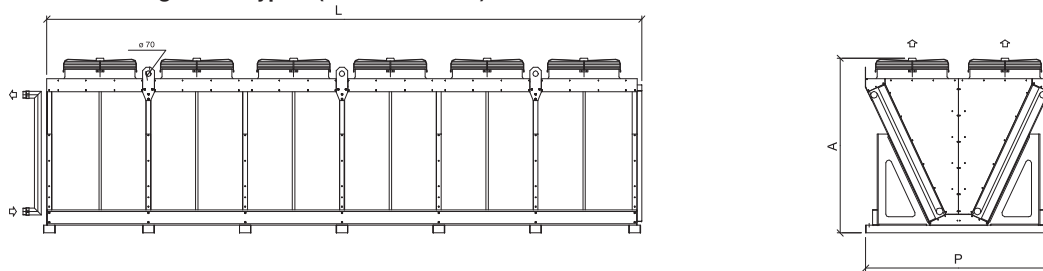

Configuration with Support Brackets Type 3 (vertical air flow)

